

Maine State Library

Digital Maine

Transportation Documents

Transportation

11-14-1928

Maine Highway Commission : Piscataquis River Bridge, Town of Howland, Penobscot Co., Transverse Bracing (6-191), November 14, 1928

Maine Department of Transportation

Follow this and additional works at: https://digitalmaine.com/mdot_docs

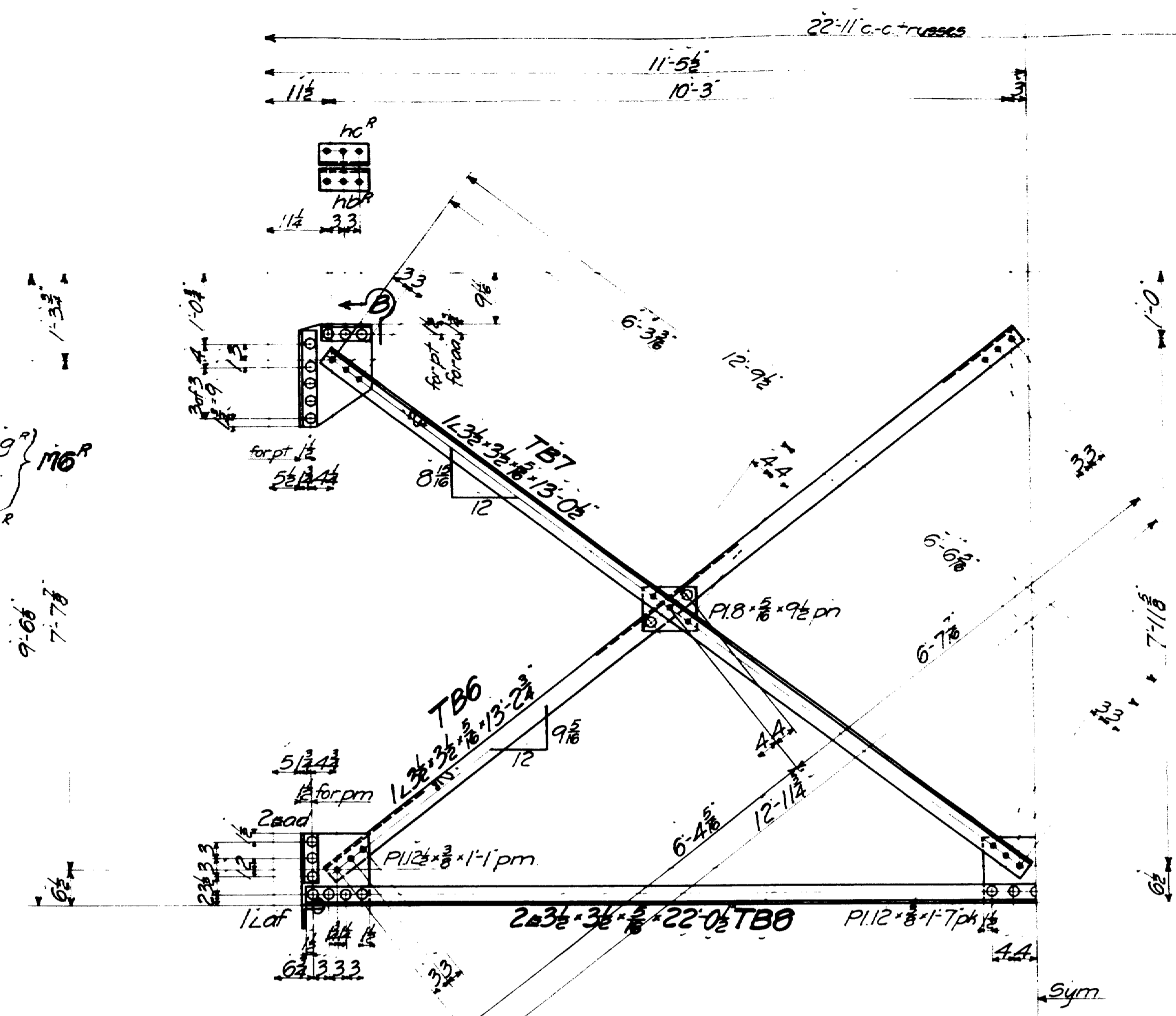
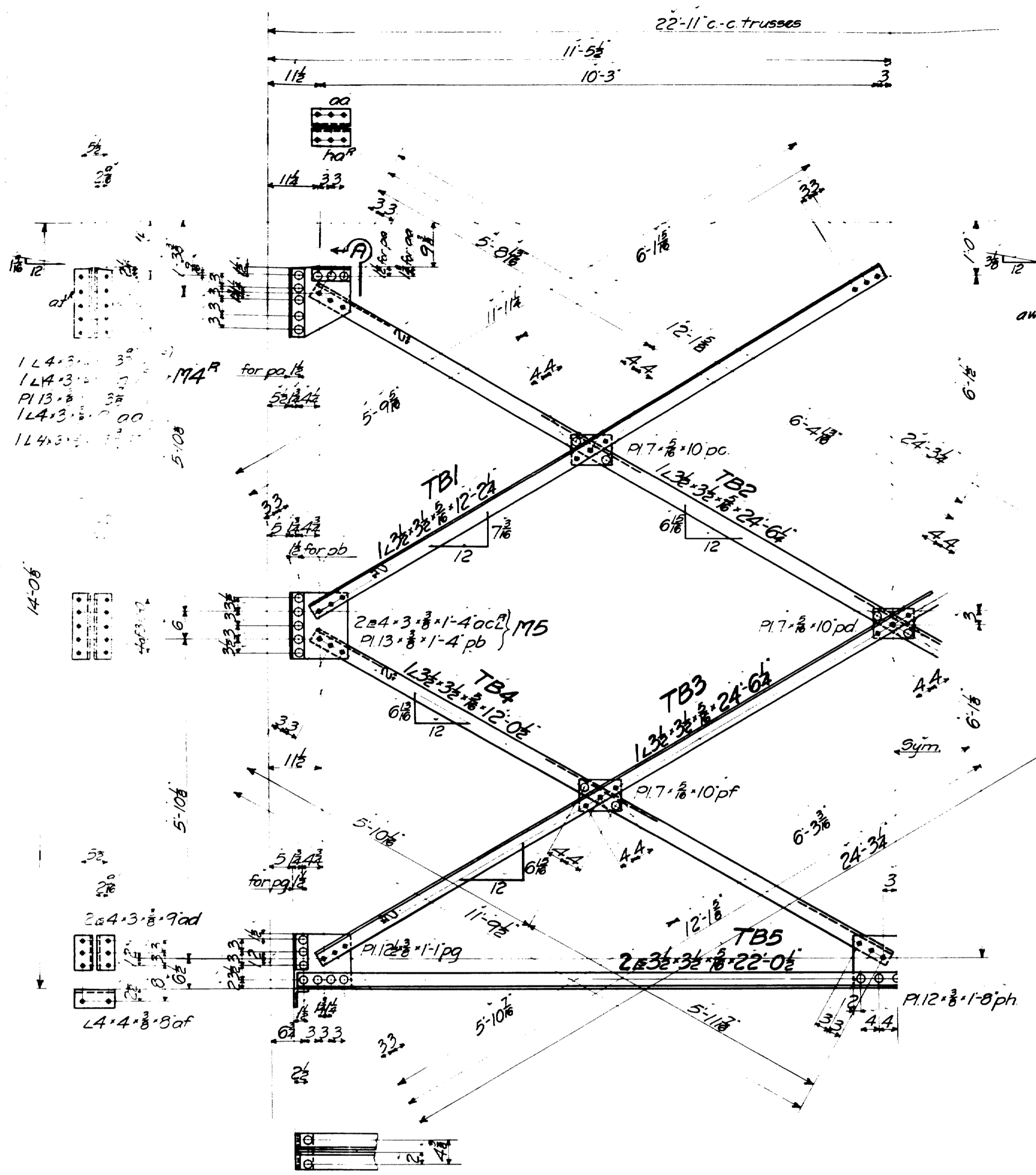

REQUIRED		
12	TRANS BRACING	TB1
6		TB2
6		TB3
12		TB4
6		TB5
12		TB6
12		TB7
6		TB8
6	PLATES	M4 ^R
6		M4 ^L
12		M5
6		M6 ^R
6		M6 ^L

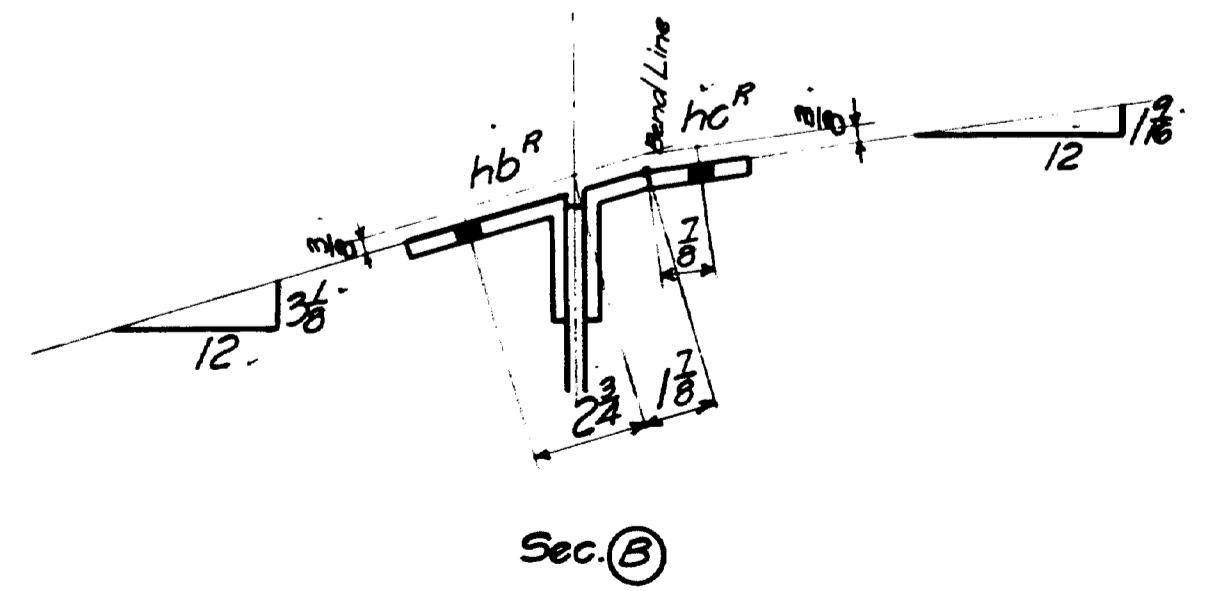
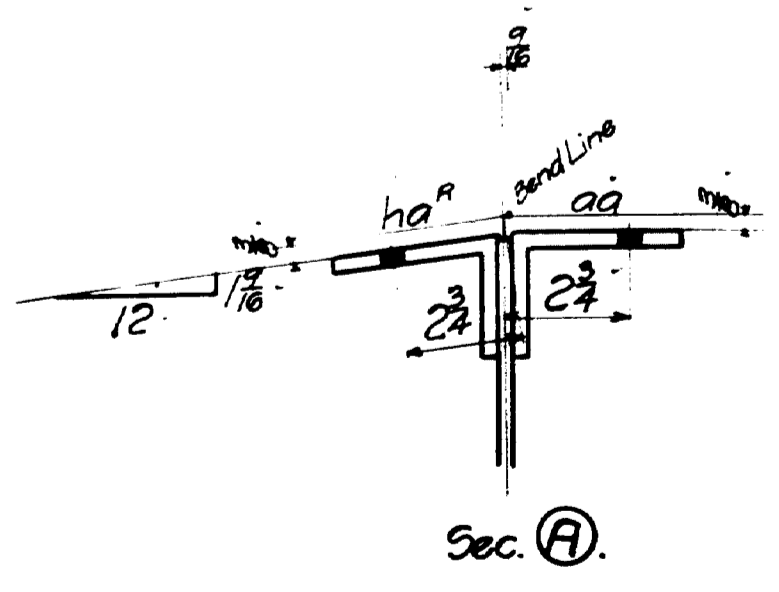

Notes:
 Rivets - 7/8"
 Holes - 1/8"
 Specifications: Maine State Hwy. Dept.
 Shop Paint: One coat Red Lead & Oil.

MAINE HIGHWAY COMMISSION
 PISCATAQUIS RIVER BRIDGE
 TOWN OF HOWLAND, PENOBSCOT CO.
 Transverse Bracing.
 Copyright, 1920.
 Elmira
 Elmira
 Beebe
 H.P.H.
 11-14-22
 11-15-22

